



**Winstar Display Co., LTD**  
**華凌光電股份有限公司**



住址: 407 台中市清江路163 號  
 No.163 Chung Ching RD.,  
 Taichung, Taiwan, R.O.C

WEB: <http://www.winstar.com.tw>  
 E-mail: [winstar@winstar.com.tw](mailto:winstar@winstar.com.tw)  
 Tel: 886-4-24262208 Fax : 886-4-24262207

**SPECIFICATION**

**CUSTOMER :** Andpol Elektronik

**MODULE NO.:** WF57ATIBCD0#000

<p><b>APPROVED BY:</b></p> <p>( FOR CUSTOMER USE ONLY )</p>	<p>PCB VERSION:          DATA:</p>
---	------------------------------------

SALES BY	APPROVED BY	CHECKED BY	PREPARED BY

ISSUED DATE:



**Winstar Display Co., LTD**

華凌光電股份有限公司

MODLE NO :

**RECORDS OF REVISION**

**DOC. FIRST ISSUE**

VERSION	DATE	REVISED PAGE NO.	SUMMARY
0	2007.04.11		First issue

# **Contents**

- 1. Module Classification Information**
- 2. Block Diagram**
- 3. Electrical Characteristics**
- 4. Absolute Maximum Ratings**
- 5. Interface Pin Function**
- 6. Timing Characteristics**
- 7. Optical Characteristics**
- 8. Contour Drawing**
- 9. LED driving conditions**
- 10. Touch panel information**
- 11. Inspection specification**
- 12. software (Register Initiate code)**

# **1. Module Classification Information**

WF 57 A T I B C D 0 #000

- ① Brand : WINSTAR DISPLAY CORPORATION
- ② Display Type : H→Character Type, G→Graphic Type F→TFT Type
- ③ Display Size : 5.7” TFT
- ④ Model serials no.
- ⑤ Backlight Type :    F→CCFL, White                      T→LED, White
  
- ⑥ LCD Polarize            A→Reflective, N.T, 6:00                      H→Transflective, W.T,6:00  
   Type/ Temperature                      D→Reflective, N.T, 12:00                      K→Transflective, W.T,12:00  
   range/ View                                      G→Reflective, W. T, 6:00                      C→Transmissive, N.T,6:00  
   direction    J→Reflective, W. T, 12:00                      F→Transmissive, N.T,12:00  
     B→Transflective, N.T,6:00                      I→Transmissive, W. T, 6:00  
     E→Transflective, N.T.12:00                      L→Transmissive, W.T,12:00
- ⑦ A: TFT LCD  
     B: TFT+FR+CONTROL BOARD  
     C: TFT+FR+A/D BOARD  
     D:TFT+FR+A/D BOARD+CONTROL BOARD
- ⑧ Solution: A: 128160    B:320234    C:320240    D:480234  
     D: Digital    A: Analog  
     Version  
     Special Code            #:Fit in with ROHS directive regulations  
                                     00:Sales code 0:Version



This product is composed of a TFT LCD panel, driver ICs, FPC, Control Board and a backlight unit. The following table described the features of WF57ATIBCD0#000.

<b>Item</b>	<b>Dimension</b>	<b>Unit</b>
Dot Matrix	320 x RGBx240(TFT)	dots
Module dimension	141.12x 102.67 x 14.2	mm
View area	117.20x 88.4	mm
Dot pitch	0.12 x 0.36	mm
Driving IC package	COG	
LCD type	TFT, Negative, Transmissive	
View direction	6 o'clock	
Backlight Type	LED, Normally White	

\*Expose the IC number blaze (Luminosity over than 1 cd) when using the LCM may cause IC operating failure.

\*Color tone slight changed by temperature and driving voltage.

## 2. Block Diagram

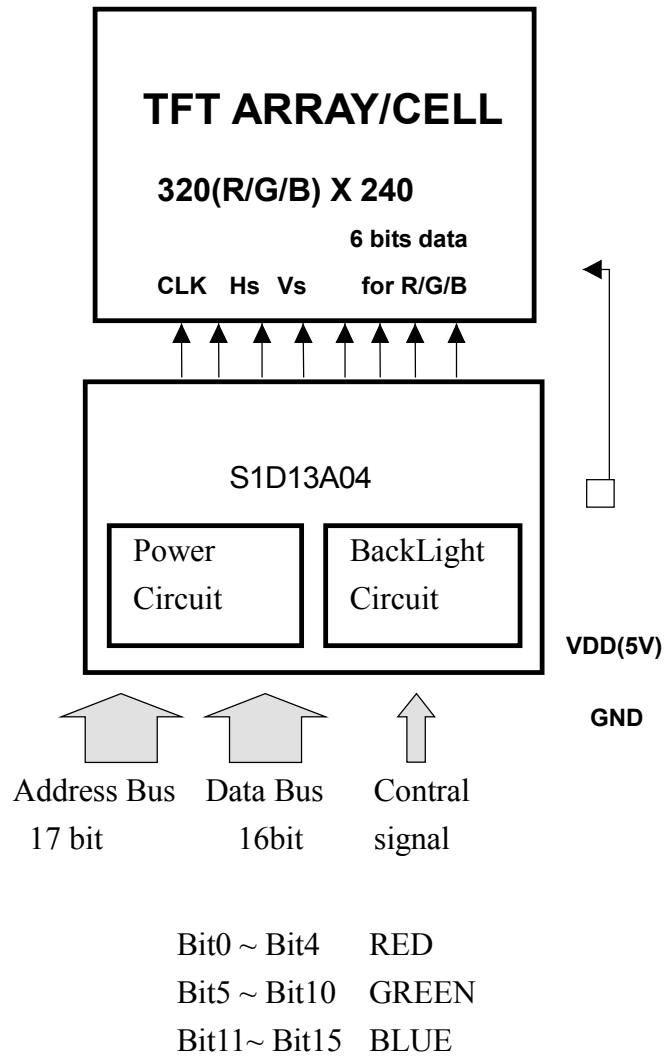

### **3.Electrical Characteristics**

Item	Symbol	Condition	Min	Typ	Max	Unit
Supply Voltage For Logic	VCC	—	3.0	3.3	3.6	V
Input High Volt.	V <sub>IH</sub>	—	0.7 V <sub>CC</sub>	—	V <sub>CC</sub>	V
Input Low Volt.	V <sub>IL</sub>	—	0	—	0.3V <sub>CC</sub>	V
Power Supply Voltage	V <sub>GH</sub>	Ta=25°C	—	15.0	—	V
	V <sub>GL</sub>	Ta=25°C	—	-10	—	V
Supply Current	I <sub>CC</sub>	V <sub>CC</sub> =5	—	250	280	mA
						(*NOTE1)

\*NOTE1:MIN. and MAX. Voltage is specified ac the voltage within the condition

Temperature rang -0°C~70°C

Typ. Voltage is specified as module driving condition : Ta=25°C ,Vop at Optimum Contrast

### **4.Absolute Maximum Ratings**

Item	Symbol	Min	Typ	Max	Unit
Operating Temperature	T <sub>OP</sub>	0	—	+70	°C
Storage Temperature	T <sub>ST</sub>	0	—	+80	°C
Power Supply Voltage	V <sub>GH</sub>	-0.3	—	18	V
	V <sub>GL</sub>	-15	—	0.3	V
	VCC	-0.3	—	6.0	V



## 5.Interface Pin Function

### 5-1 Pins Connection To Control Board

P/N	Symbol	Function	P/N	Symbol	Function
1	Vcc	Power Supply : +5V	26	GND	Ground for logic circuit
2	BL_C	Backlight control signal	27	NC	No Connection
3	DB0	Input data from the system data bus.	28	GND	Ground for logic circuit
4	DB1		29	AD0	System address bus bits
5	DB2		30	GND	Ground for logic circuit
6	DB3		31	AD1	System address bus bits
7	DB4		32	GND	Ground for logic circuit
8	DB5		33	AD2	System address bus bits
9	DB6		34	GND	Ground for logic circuit
10	DB7		35	AD3	System address bus bits
11	DB8		36	GND	Ground for logic circuit
12	DB9		37	AD4	System address bus bits
13	DB10		38	AD5	
14	DB11		39	AD6	
15	DB12		40	AD7	
16	DB13		41	AD8	
17	DB14		42	AD9	
18	DB15	43	AD10		
19	CS	Chip select input.	44	AD11	
20	MR	See Note(1)	45	AD12	
21	RD	this pin inputs the read command	46	AD13	
22	WR	write enable signal	47	AD14	
23	BHE	This pin inputs the byte enable signal for the high data byte	48	AD15	
24	REST	Active low input to set all internal registers to the default state	49	AD16	
25	WAIT	This pin outputs the wait signal	50	AD17	

Note(1): This input pin is used to select between the display buffer and register address spaces of the

S1D13A04. M/R# is set high to access the display buffer and low to access the registers.

## 6. Timing Characteristics

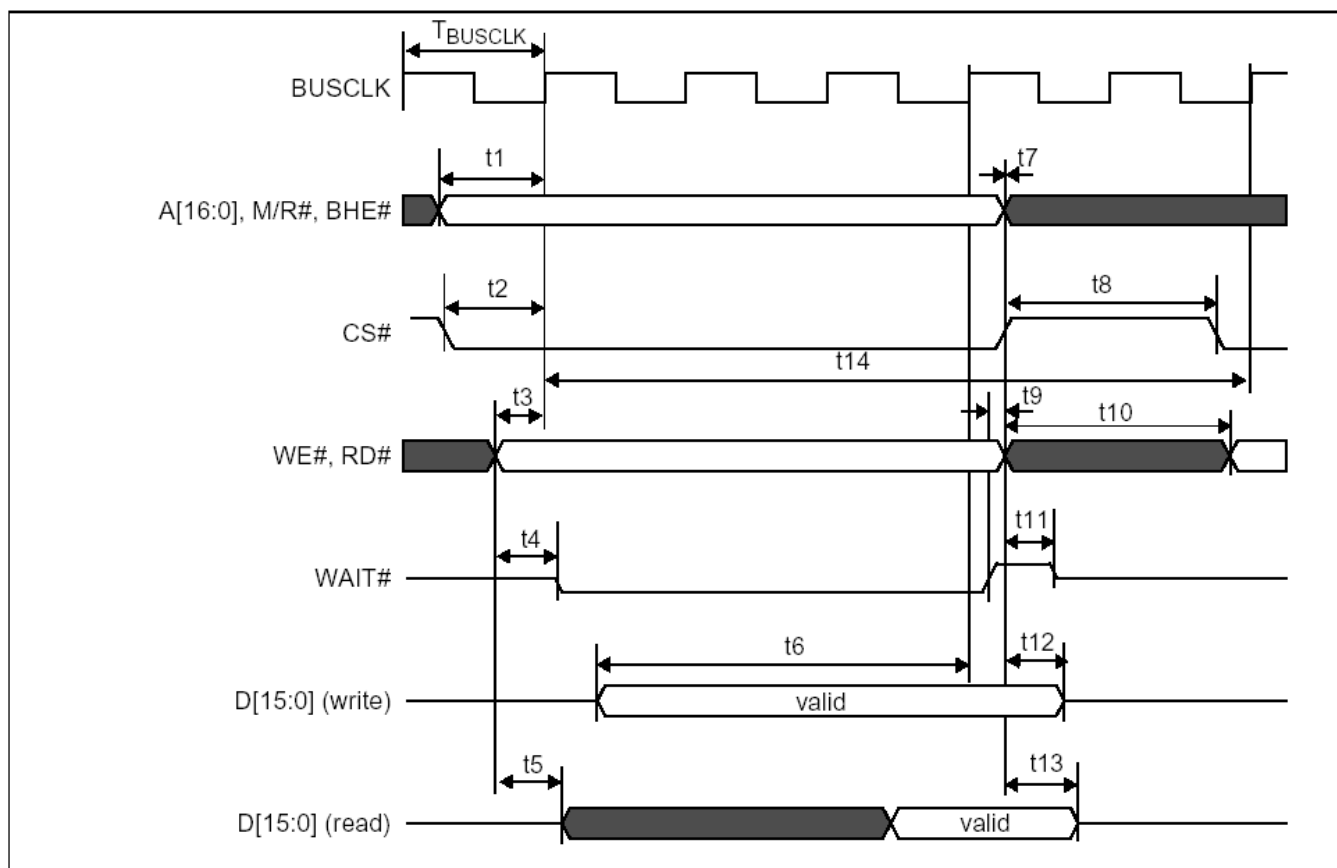

6-1. Interface Timing

Symbol	Parameter	Min	Max	Unit
$f_{\text{BUSCLK}}$	Bus clock frequency		50	MHz
$T_{\text{BUSCLK}}$	Bus clock period	$1/f_{\text{BUSCLK}}$		ns
t1	A[16:0], M/R#, BHE# setup to first BUSCLK rising edge where CS# = 0 and either RD# = 0 or WE# = 0	9		ns
t2	CS# setup to BUSCLK rising edge	9		ns
t3	RD#, WE# setup to BUSCLK rising edge	1		ns
t4	RD# or WE# state change to WAIT# driven low	1	10	ns
t5	RD# falling edge to D[15:0] driven (read cycle)	2	10	ns
t6	D[15:0] setup to 4th rising BUSCLK edge after CS#=0 and WE#=0	1		$T_{\text{BUSCLK}}$
t7	A[16:0], M/R#, BHE# and CS# hold from RD#, WE# rising edge	0		ns
t8	CS# deasserted to reasserted	0		ns
t9	WAIT# rising edge to RD#, WE# rising edge	0		ns
t10	WE#, RD# deasserted to reasserted	1		$T_{\text{BUSCLK}}$
t11	Rising edge of either RD# or WE# to WAIT# high impedance		0.5	$T_{\text{BUSCLK}}$
t12	D[15:0] hold from WE# rising edge (write cycle)	2		ns
t13	D[15:0] hold from RD# rising edge (read cycle)	1		ns
t14	Cycle Length	6		$T_{\text{BUSCLK}}$

## 6-2. Interface Truth Table for Little Endian

WE#	RD#	BHE#	A0	D[15:8]	D[7:0]	Comments
0	1	0	0	valid	valid	16-bit write
0	1	1	0	-	valid	8-bit write at even address
0	1	0	1	valid	-	8-bit write at odd address
1	0	0	0	valid	valid	16-bit read
1	0	1	0	-	valid	8-bit read at even address
1	0	0	1	valid	-	8-bit read at odd address

## **7.Optical Characteristics**

Item	Symbol	Condition	Min.	Typ.	Max.	Unit	Remark
Viewing angle (CR≥10)	$\theta_L$	$\Phi=180^\circ$ (9 o'clock)	55	65	-	degree	Note 1
	$\theta_R$	$\Phi=0^\circ$ (3 o'clock)	55	65	-		
	$\theta_T$	$\Phi=90^\circ$ (12 o'clock)	35	45	-		
	$\theta_B$	$\Phi=270^\circ$ (6 o'clock)	55	65	-		
Response Time	$T_{ON}$	Normal $\theta=\Phi=0^\circ$	-	15	30	msec	Note 3
	$T_{OFF}$		-	20	50	msec	Note 3
Contrast ratio	CR		200	300	-	-	Note 4
Color chromaticity	$W_X$		-	(0.33)	-	-	Note 5
	$W_Y$		-	(0.36)	-	-	Note 6
Luminance	L		150	200	-	cd/m <sup>2</sup>	Note 6
Luminance uniformity	$Y_U$		70	75	-	%	Note 7

Test Conditions:

1.  $V_{CC}=3.3V$ ,  $AV_{DD}=5.0V$ ,  $I_L=20mA$  (Backlight current), the ambient temperature is 25°C.
2. The test systems refer to Note 2.

## 7.1 Definition of optical characteristics

Note 1: Definition of viewing angle range

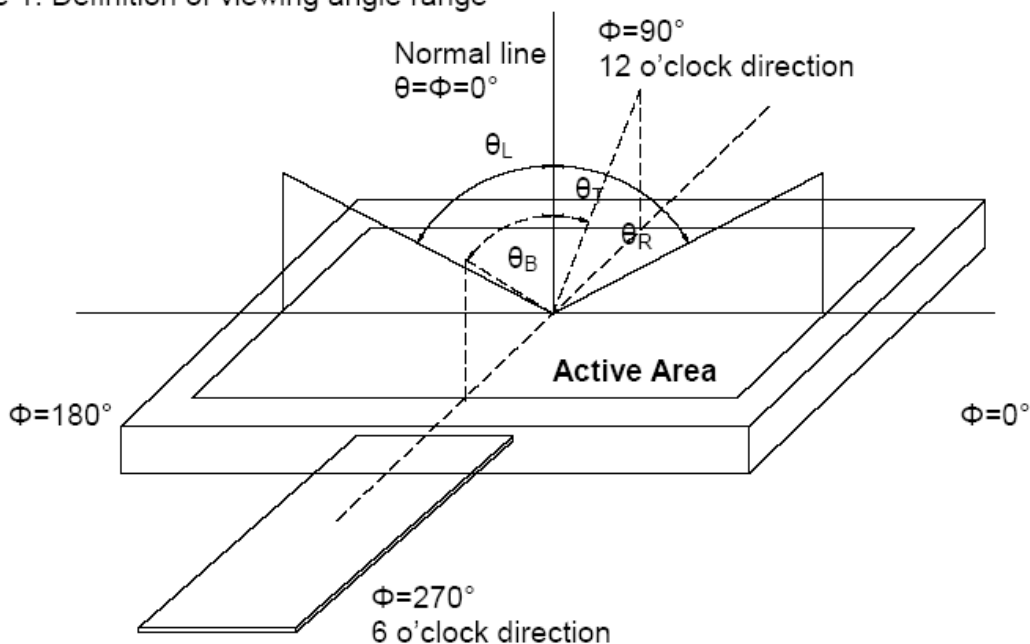

Fig. 5-1 Definition of viewing angle

Note 2: Definition of optical measurement system.

The optical characteristics should be measured in dark room. The optical properties are measured at the center point of the LCD screen. (Response time is measured by Photo detector TOPCON BM-7, other items are measured by BM-5A/Field of view:  $1^\circ$  /Height: 500mm.)

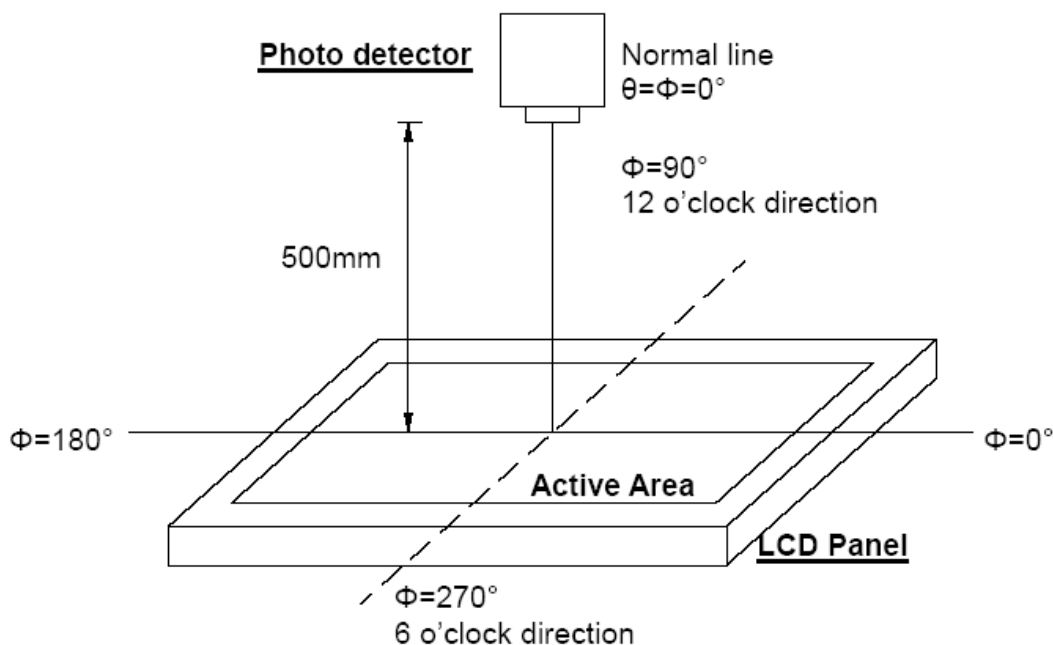

Fig. 5-2 Optical measurement system setup

The copyright belongs to InnoLux. Any unauthorized use is prohibited.

Note 3: Definition of Response time

The response time is defined as the LCD optical switching time interval between "White" state and "Black" state. Rise time ( $T_{ON}$ ) is the time between photo detector output intensity changed from 90% to 10%. And fall time ( $T_{OFF}$ ) is the time between photo detector output intensity changed from 10% to 90%.

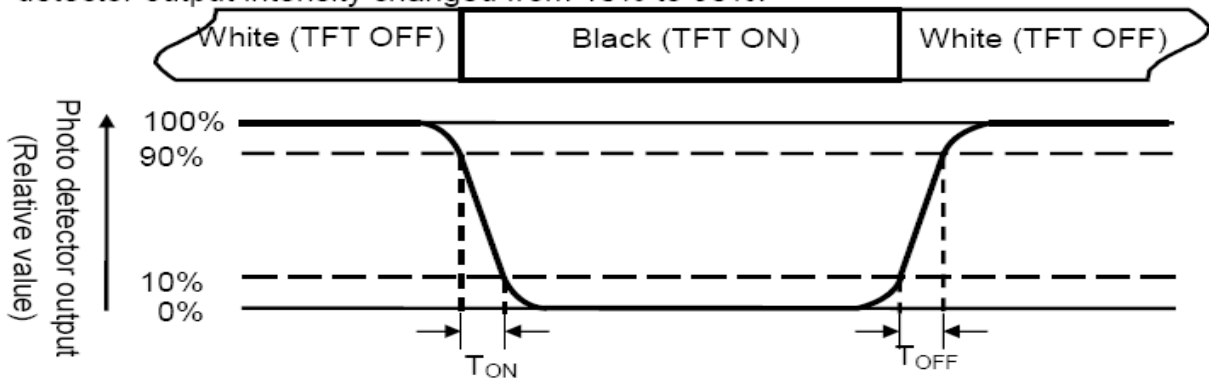

Fig. 5-3 Definition of response time

Note 4: Definition of contrast ratio

$$\text{Contrast ratio (CR)} = \frac{\text{Luminance measured when LCD is on the "White" state}}{\text{Luminance measured when LCD is on the "Black" state}}$$

Note 5: Definition of color chromaticity (CIE1931)

Color coordinates measured at center point of LCD.

Note 6: All input terminals LCD panel must be ground when measuring the center area of the panel.

Note 7: Definition of Luminance Uniformity

To test for uniformity, the tested area, which is inside the active area, is divided into 3 rows and 3 columns. The measurement spot is placed at the center of each box.

$$\text{Luminance Uniformity (Yu)} = \frac{B_{min}}{B_{max}}$$

L-----Active area length      W----- Active area width

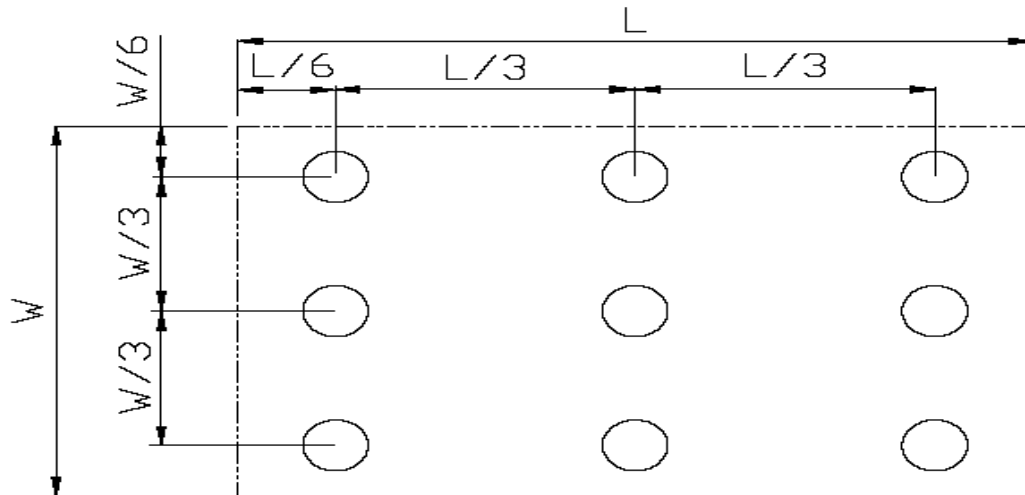
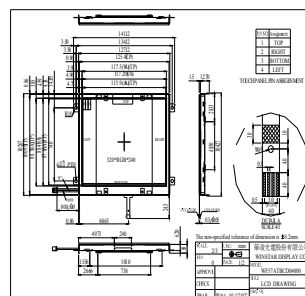

Fig. 5-4 Definition of uniformity

**B<sub>max</sub>**: The measured maximum luminance of all measurement position.

**B<sub>min</sub>**: The measured minimum luminance of all measurement position.

## 8. Contour Drawing







## 9. LED driving conditions

Parameter	Symbol	Min.	Typ.	Max.	Unit	Remark
LED current	$I_{LED}$		140	210	mA	Note 1
LED voltage	$V_{LED}$	9.9	-	10.5	V	
LED Life Time	-	(10,000)	-	-	Hr	Note 2,3

Note 1 : There are 7 Groups LED shown as below ,  $V_{LED}=9.9V$  (min.).

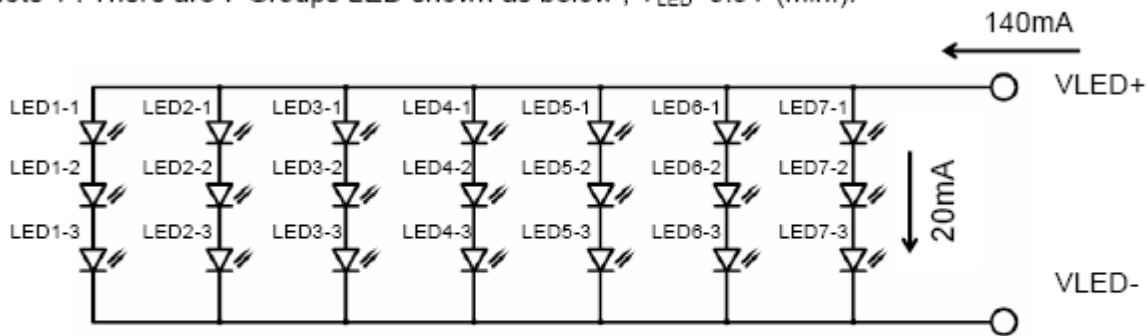

Note 2 :  $T_a = 25^{\circ}C$  ,

Note 3 : Brightness to be decreased to 50% of the initial value.

## 10. Touch panel Information

### 10.1 Dimension

<b>Outside Dimension</b>	125.40mm*100.95mm
<b>View Area</b>	117.50mm*88.70mm
<b>Active Area</b>	115.90mm*87.10mm
<b>Total thickness</b>	1.5±0.15mm
<b>Tail length</b>	24.5mm
<b>Connector</b>	FPC,4-PIN,Ptich:1.0mm
	Thickness:0.3±0.05mm
	Width: 4.0±0.2mm

### 10.2 Operating and Storage Condition

<b>Operating Temperature and Humidity</b>	0°C to 50°C, 70%RH or lower
<b>Storage Temperature and Humidity</b>	-20°C to 70°C, 90%RH or lower

### 10.3 Electrical Performance

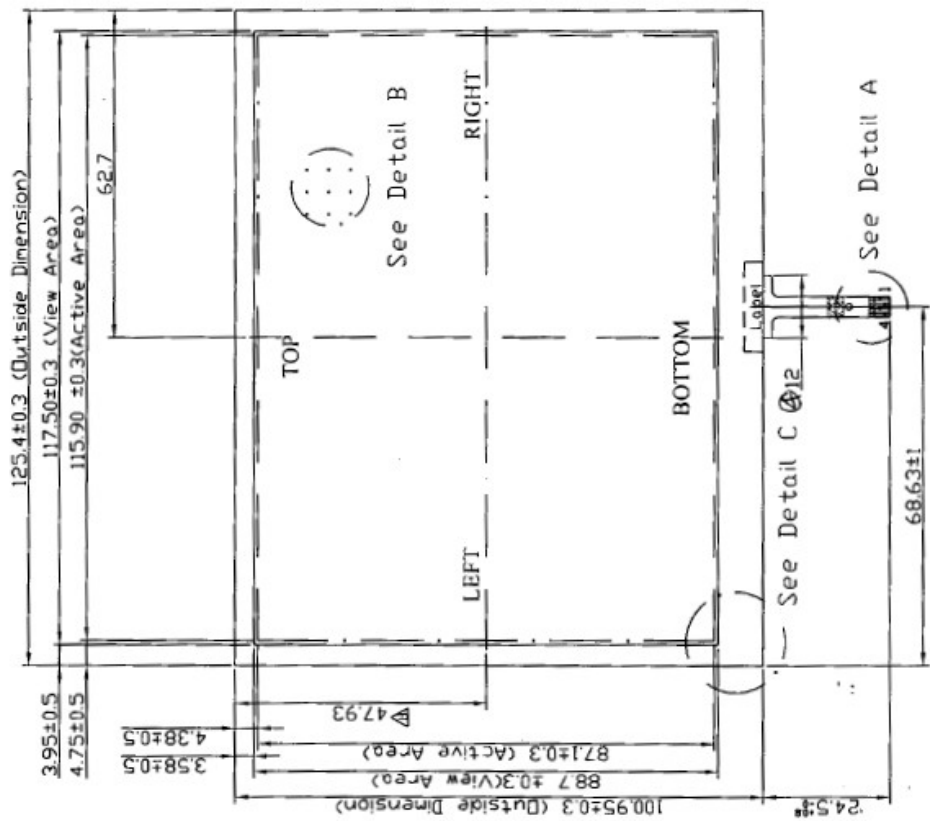

<b>Operating Voltage</b>	DC5V or less
<b>Terminal Resistance</b>	X direction 200Ω~900Ω
	Y direction 200Ω~900Ω
<b>Linearity</b>	1.5% or less
<b>Insulation Resistance</b>	20MΩ or more at DC25V
<b>Chatting</b>	10ms or less at ON/OFF
	(Test Conditions)
	R 8.0mm silicon finger hardness 60 <sup>0</sup> ,loading 250g. Measure by TD210 digital real-time oscilloscope.

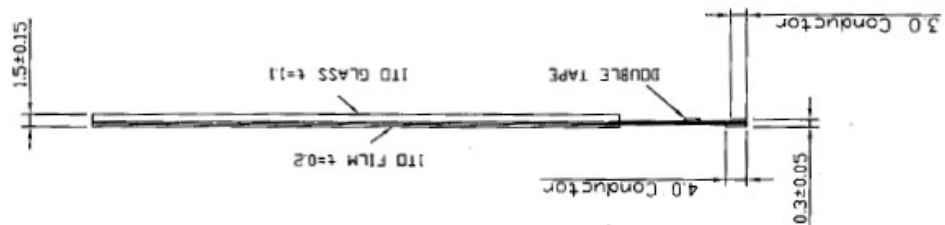
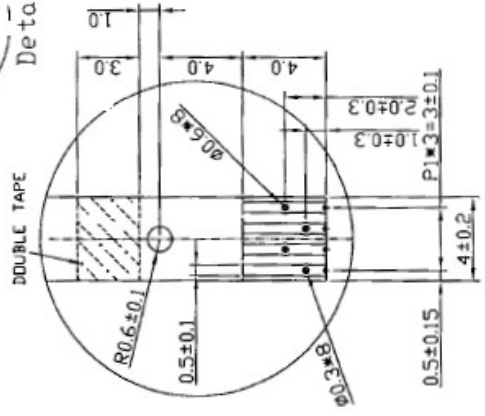
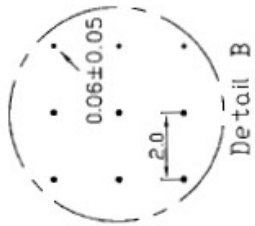
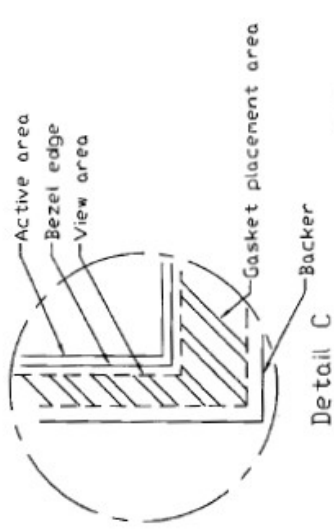

Assignment
1 TOP
2 RIGHT
3 BOTTOM
4 LEFT

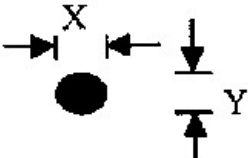

# 11. Inspection specification

NO	Item	Criterion	AQL												
01	Electrical  Testing	1.1 Missing vertical, horizontal segment, segment contrast defect. 1.2 Missing character , dot or icon. 1.3 Display malfunction. 1.4 No function or no display. 1.5 Current consumption exceeds product specifications. 1.6 LCD viewing angle defect. 1.7 Mixed product types. 1.8 Contrast defect.	0.65												
02	Black or white spots on LCD (display only)	2.1 White and black spots on display $\leq 0.25\text{mm}$ , no more than three white or black spots present. 2.2 Densely spaced: No more than two spots or lines within 3mm	2.5												
03	LCD black spots, white spots, contamination (non-display)	3.1 Round type : As following drawing $\Phi = (x + y) / 2$  <table border="1" data-bbox="874 1093 1353 1305"> <thead> <tr> <th>SIZE</th> <th>Acceptable Q TY</th> </tr> </thead> <tbody> <tr> <td><math>\Phi \leq 0.10</math></td> <td>Accept no dense</td> </tr> <tr> <td><math>0.10 &lt; \Phi \leq 0.20</math></td> <td>2</td> </tr> <tr> <td><math>0.20 &lt; \Phi \leq 0.25</math></td> <td>1</td> </tr> <tr> <td><math>0.25 &lt; \Phi</math></td> <td>0</td> </tr> </tbody> </table>	SIZE	Acceptable Q TY	$\Phi \leq 0.10$	Accept no dense	$0.10 < \Phi \leq 0.20$	2	$0.20 < \Phi \leq 0.25$	1	$0.25 < \Phi$	0	2.5		
		SIZE	Acceptable Q TY												
$\Phi \leq 0.10$	Accept no dense														
$0.10 < \Phi \leq 0.20$	2														
$0.20 < \Phi \leq 0.25$	1														
$0.25 < \Phi$	0														
3.2 Line type : (As following drawing) <table border="1" data-bbox="707 1420 1353 1630"> <thead> <tr> <th>Length</th> <th>Width</th> <th>Acceptable Q TY</th> </tr> </thead> <tbody> <tr> <td>---</td> <td><math>W \leq 0.02</math></td> <td>Accept no dense</td> </tr> <tr> <td><math>L \leq 3.0</math></td> <td><math>0.02 &lt; W \leq 0.03</math></td> <td rowspan="2">2</td> </tr> <tr> <td><math>L \leq 2.5</math></td> <td><math>0.03 &lt; W \leq 0.05</math></td> </tr> <tr> <td>---</td> <td><math>0.05 &lt; W</math></td> <td>As round type</td> </tr> </tbody> </table> 	Length	Width	Acceptable Q TY	---	$W \leq 0.02$	Accept no dense	$L \leq 3.0$	$0.02 < W \leq 0.03$	2	$L \leq 2.5$	$0.03 < W \leq 0.05$	---	$0.05 < W$	As round type	2.5
Length	Width	Acceptable Q TY													
---	$W \leq 0.02$	Accept no dense													
$L \leq 3.0$	$0.02 < W \leq 0.03$	2													
$L \leq 2.5$	$0.03 < W \leq 0.05$														
---	$0.05 < W$	As round type													

04	Polarizer bubbles	If bubbles are visible, judge using black spot specifications, not easy to find, must check in specify direction.	<table border="1"> <thead> <tr> <th>Size <math>\Phi</math></th> <th>Acceptable Q TY</th> </tr> </thead> <tbody> <tr> <td><math>\Phi \leq 0.20</math></td> <td>Accept no dense</td> </tr> <tr> <td><math>0.20 &lt; \Phi \leq 0.50</math></td> <td>3</td> </tr> <tr> <td><math>0.50 &lt; \Phi \leq 1.00</math></td> <td>2</td> </tr> <tr> <td><math>1.00 &lt; \Phi</math></td> <td>0</td> </tr> <tr> <td>Total Q TY</td> <td>3</td> </tr> </tbody> </table>	Size $\Phi$	Acceptable Q TY	$\Phi \leq 0.20$	Accept no dense	$0.20 < \Phi \leq 0.50$	3	$0.50 < \Phi \leq 1.00$	2	$1.00 < \Phi$	0	Total Q TY	3	2.5
Size $\Phi$	Acceptable Q TY															
$\Phi \leq 0.20$	Accept no dense															
$0.20 < \Phi \leq 0.50$	3															
$0.50 < \Phi \leq 1.00$	2															
$1.00 < \Phi$	0															
Total Q TY	3															

NO	Item	Criterion	AQL
05	Scratches	Follow NO.3 LCD black spots, white spots, contamination	

Symbols Define:

x: Chip length    y: Chip width    z: Chip thickness  
 k: Seal width    t: Glass thickness    a: LCD side length  
 L: Electrode pad length:

6.1 General glass chip :

6.1.1 Chip on panel surface and crack between panels:

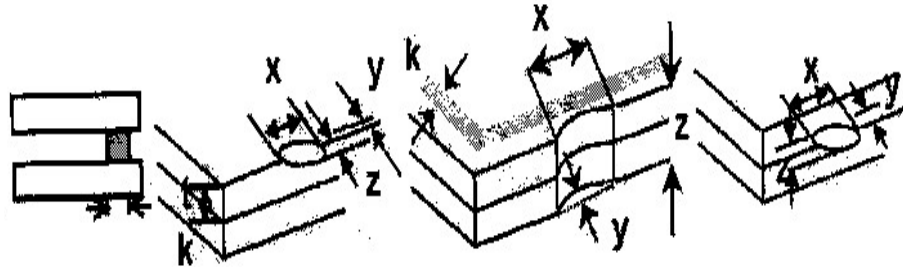

z: Chip thickness	y: Chip width	x: Chip length
$Z \leq 1/2t$	Not over viewing area	$x \leq 1/8a$
$1/2t < z \leq 2t$	Not exceed $1/3k$	$x \leq 1/8a$

⊙If there are 2 or more chips, x is total length of each chip.

6.1.2 Corner crack:

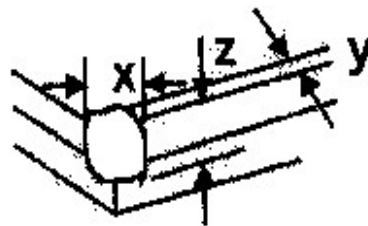

z: Chip thickness	y: Chip width	x: Chip length
$Z \leq 1/2t$	Not over viewing area	$x \leq 1/8a$
$1/2t < z \leq 2t$	Not exceed $1/3k$	$x \leq 1/8a$

⊙If there are 2 or more chips, x is the total length of each chip.

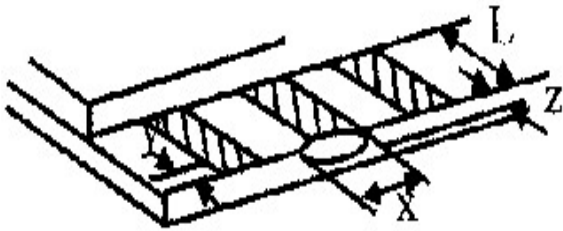
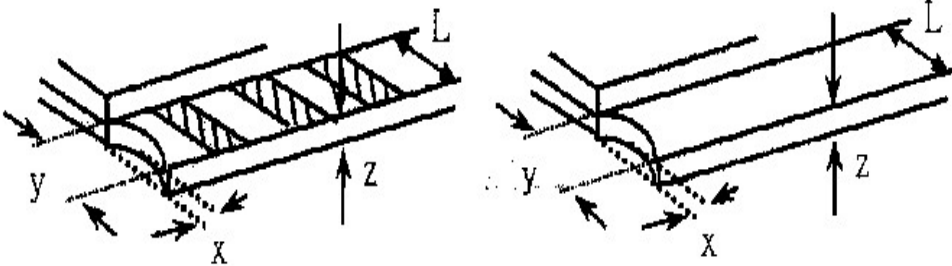
NO	Item	Criterion	AQL													
06	Glass crack	<p>Symbols :</p> <p>x: Chip length    y: Chip width    z: Chip thickness</p> <p>k: Seal width    t: Glass thickness    a: LCD side length</p> <p>L: Electrode pad length</p> <p>6.2 Protrusion over terminal :</p> <p>6.2.1 Chip on electrode pad :</p> <div style="text-align: center;">  </div> <table border="1" style="margin: 10px auto; border-collapse: collapse;"> <tr> <td style="padding: 5px;">y: Chip width</td> <td style="padding: 5px;">x: Chip length</td> <td style="padding: 5px;">z: Chip thickness</td> <td rowspan="2" style="padding: 5px; vertical-align: middle;">6.2.2</td> </tr> <tr> <td style="padding: 5px;"><math>y \leq 0.5\text{mm}</math></td> <td style="padding: 5px;"><math>x \leq 1/8a</math></td> <td style="padding: 5px;"><math>0 &lt; z \leq t</math></td> </tr> </table> <p>Non-conductive portion:</p> <div style="text-align: center;">  </div> <table border="1" style="margin: 10px auto; border-collapse: collapse;"> <tr> <td style="padding: 5px;">y: Chip width</td> <td style="padding: 5px;">x: Chip length</td> <td style="padding: 5px;">z: Chip thickness</td> </tr> <tr> <td style="padding: 5px;"><math>y \leq L</math></td> <td style="padding: 5px;"><math>x \leq 1/8a</math></td> <td style="padding: 5px;"><math>0 &lt; z \leq t</math></td> </tr> </table> <p>⊙If the chipped area touches the ITO terminal, over 2/3 of the ITO must remain and be inspected according to electrode terminal specifications.</p> <p>⊙If the product will be heat sealed by the customer, the alignment mark not be damaged.</p> <p>6.2.3 Substrate protuberance and internal crack.</p>	y: Chip width	x: Chip length	z: Chip thickness	6.2.2	$y \leq 0.5\text{mm}$	$x \leq 1/8a$	$0 < z \leq t$	y: Chip width	x: Chip length	z: Chip thickness	$y \leq L$	$x \leq 1/8a$	$0 < z \leq t$	2.5
y: Chip width	x: Chip length	z: Chip thickness	6.2.2													
$y \leq 0.5\text{mm}$	$x \leq 1/8a$	$0 < z \leq t$														
y: Chip width	x: Chip length	z: Chip thickness														
$y \leq L$	$x \leq 1/8a$	$0 < z \leq t$														



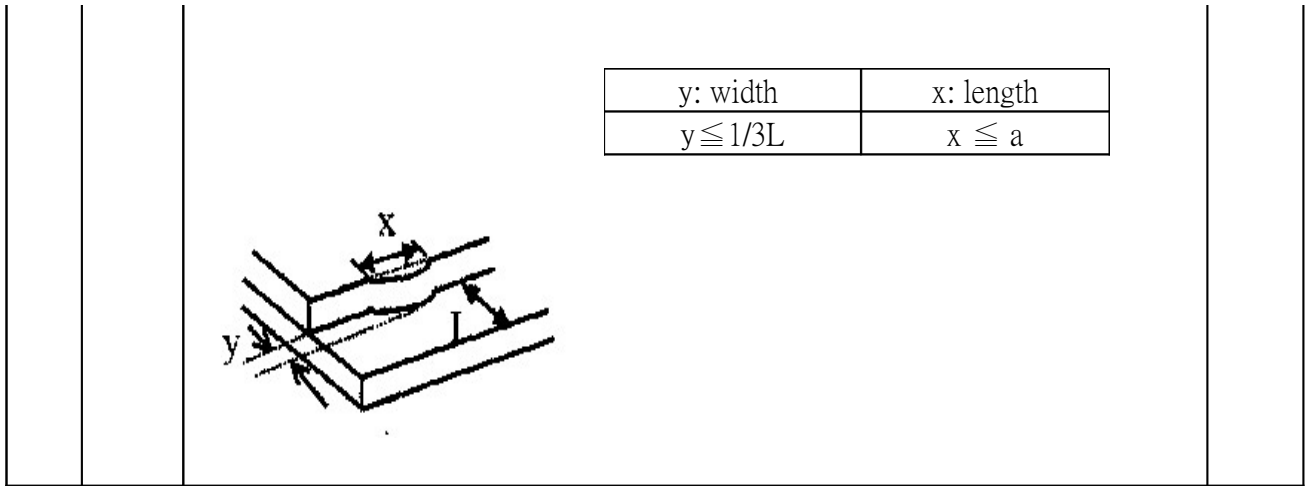

NO	Item	Criterion	AQL
07	Cracked glass	The LCD with extensive crack is not acceptable.	2.5
08	Backlight elements	8.1 Illumination source flickers when lit. 8.2 Spots or scratched that appear when lit must be judged. Using LCD spot, lines and contamination standards. 8.3 Backlight doesn't light or color wrong.	0.65  2.5  0.65
09	Bezel	9.1 Bezel may not have rust, be deformed or have fingerprints, stains or other contamination. 9.2 Bezel must comply with job specifications.	2.5  0.65
10	PCB、COB	10.1 COB seal may not have pinholes larger than 0.2mm or contamination. 10.2 COB seal surface may not have pinholes through to the IC. 10.3 The height of the COB should not exceed the height indicated in the assembly diagram.	2.5  2.5  0.65

		10.4 There may not be more than 2mm of sealant outside the seal area on the PCB. And there should be no more than three places.	2.5
		10.5 No oxidation or contamination PCB terminals.	2.5
		10.6 Parts on PCB must be the same as on the production characteristic chart. There should be no wrong parts, missing parts or excess parts.	0.65
		10.7 The jumper on the PCB should conform to the product characteristic chart.	0.65
		10.8 If solder gets on bezel tab pads, LED pad, zebra pad or screw hold pad, make sure it is smoothed down.	2.5
11	Soldering	11.1 No un-melted solder paste may be present on the PCB.	2.5
		11.2 No cold solder joints, missing solder connections, oxidation or icicle.	2.5
		11.3 No residue or solder balls on PCB.	2.5
		11.4 No short circuits in components on PCB.	0.65

NO	Item	Criterion	AQL
12	General appearance	12.1 No oxidation, contamination, curves or, bends on interface Pin (OLB) of TCP.	2.5
		12.2 No cracks on interface pin (OLB) of TCP.	0.65
		12.3 No contamination, solder residue or solder balls on product.	2.5
		12.4 The IC on the TCP may not be damaged, circuits.	2.5
		12.5 The uppermost edge of the protective strip on the interface pin must be present or look as if it cause the interface pin to sever.	2.5
		12.6 The residual rosin or tin oil of soldering (component or chip	2.5

		component) is not burned into brown or black color.	
		12.7 Sealant on top of the ITO circuit has not hardened.	2.5
		12.8 Pin type must match type in specification sheet.	0.65
		12.9 LCD pin loose or missing pins.	0.65
		12.10 Product packaging must the same as specified on packaging specification sheet.	0.65
		12.11 Product dimension and structure must conform to product specification sheet.	0.65

## 12. software (Register Initiate code)

```
{ \
{ 0x14,      0x00000000 }, /* Power Save Configuration Register      */ \
{ 0x64,      0x28D70000 }, /* GPIO Status and Control Register      */ \
```

```

{ 0x04,      0x00000000 }, /* Memory Clock Configuration Register      */ \
{ 0x08,      0x00000032 }, /* Pixel Clock Configuration Register        */ \
{ 0x0C,      0x00000061 }, /* Panel Type and MOD Rate Register         */ \
{ 0x10,      0x00000010 }, /* Display Settings Register                */ \
{ 0x20,      0x00000030 }, /* Horizontal Total Register                */ \
{ 0x24,      0x00000027 }, /* Horizontal Display Period Register       */ \
{ 0x28,      0x0000000F }, /* Horizontal Display Period Start Position Register */ \
{ 0x2C,      0x00870156 }, /* FPLINE Register                         */ \
{ 0x30,      0x00000103 }, /* Vertical Total Register                  */ \
{ 0x34,      0x000000EF }, /* Vertical Display Period Register        */ \
{ 0x38,      0x00000013 }, /* Vertical Display Period Start Position Register */ \
{ 0x3C,      0x00800000 }, /* FPFRAME Register                       */ \
{ 0x40,      0x00000000 }, /* Main Window Display Start Address Register */ \
{ 0x44,      0x000000A0 }, /* Main Window Line Address Offset Register */ \
{ 0x50,      0x00000000 }, /* PIP+ Window Display Start Address Register */ \
{ 0x54,      0x000000A0 }, /* PIP+ Window Line Address Offset Register */ \
{ 0x58,      0x00000000 }, /* PIP+ Window X Positions Register        */ \
{ 0x5C,      0x00000000 }, /* PIP+ Window Y Positions Register        */ \
{ 0x60,      0x00000000 }, /* Special Purpose Register                */ \
{ 0x70,      0x00000000 }, /* PWM Clock Configuration Register        */ \
{ 0x74,      0x00000000 }, /* PWMOUT Duty Cycle Register              */ \
{ 0x80,      0x00000000 }, /* Scratch Pad A Register                  */ \
{ 0x84,      0x00000000 }, /* Scratch Pad B Register                  */ \
{ 0x88,      0x00000000 }, /* Scratch Pad C Register                  */ \
{ SID_REGDELAYON, 0x00000032 }, /* LCD Panel Power On Delay (in ms)        */ \
{ 0x64,      0x28D70001 }, /* GPIO Status and Control Register        */ \
{ 0x14,      0x00000000 } /* Power Save Configuration Register      */ \
}

```



## winstar LCM Sample Estimate Feedback Sheet

Module Number : \_\_\_\_\_

Page: 1

### 1、Panel Specification :

1. Panel Type :  Pass  NG ,\_\_\_\_\_
2. View Direction :  Pass  NG ,\_\_\_\_\_
3. Numbers of Dots :  Pass  NG ,\_\_\_\_\_
4. View Area :  Pass  NG ,\_\_\_\_\_
5. Active Area :  Pass  NG ,\_\_\_\_\_
6. Operating Temperature :  Pass  NG ,\_\_\_\_\_
7. Storage Temperature :  Pass  NG ,\_\_\_\_\_
8. Others : \_\_\_\_\_

## 2、Mechanical Specification :

1. PCB Size :  Pass  NG ,\_\_\_\_\_
2. Frame Size :  Pass  NG ,\_\_\_\_\_
3. Material of Frame :  Pass  NG ,\_\_\_\_\_
4. Connector Position :  Pass  NG ,\_\_\_\_\_
5. Fix Hole Position :  Pass  NG ,\_\_\_\_\_
6. Backlight Position :  Pass  NG ,\_\_\_\_\_
7. Thickness of PCB :  Pass  NG ,\_\_\_\_\_
8. Height of Frame to PCB :  Pass  NG ,\_\_\_\_\_
9. Height of Module :  Pass  NG ,\_\_\_\_\_
10. Others :  Pass  NG ,\_\_\_\_\_

## 3、Relative Hole Size :

1. Pitch of Connector :  Pass  NG ,\_\_\_\_\_
2. Hole size of Connector :  Pass  NG ,\_\_\_\_\_
3. Mounting Hole size :  Pass  NG ,\_\_\_\_\_
4. Mounting Hole Type :  Pass  NG ,\_\_\_\_\_
5. Others :  Pass  NG ,\_\_\_\_\_

## 4、Backlight Specification :

1. B/L Type :  Pass  NG ,\_\_\_\_\_
2. B/L Color :  Pass  NG ,\_\_\_\_\_
3. B/L Driving Voltage (Reference for LED Type) :  Pass  NG ,\_\_\_\_\_
4. B/L Driving Current :  Pass  NG ,\_\_\_\_\_
5. Brightness of B/L :  Pass  NG ,\_\_\_\_\_
6. B/L Solder Method :  Pass  NG ,\_\_\_\_\_
7. Others :  Pass  NG ,\_\_\_\_\_

>> Go to page 2 <<



Module Number : \_\_\_\_\_

Page: 2

**5、Electronic Characteristics of Module：**

- |                             |                               |                                    |
|-----------------------------|-------------------------------|------------------------------------|
| 1. Input Voltage：           | <input type="checkbox"/> Pass | <input type="checkbox"/> NG ,_____ |
| 2. Supply Current：          | <input type="checkbox"/> Pass | <input type="checkbox"/> NG ,_____ |
| 3. Driving Voltage for LCD： | <input type="checkbox"/> Pass | <input type="checkbox"/> NG ,_____ |
| 4. Contrast for LCD：        | <input type="checkbox"/> Pass | <input type="checkbox"/> NG ,_____ |
| 5. B/L Driving Method：      | <input type="checkbox"/> Pass | <input type="checkbox"/> NG ,_____ |
| 6. Negative Voltage Output： | <input type="checkbox"/> Pass | <input type="checkbox"/> NG ,_____ |
| 7. Interface Function：      | <input type="checkbox"/> Pass | <input type="checkbox"/> NG ,_____ |
| 8. LCD Uniformity：          | <input type="checkbox"/> Pass | <input type="checkbox"/> NG ,_____ |
| 9. ESD test：                | <input type="checkbox"/> Pass | <input type="checkbox"/> NG ,_____ |
| 10. Others：                 | <input type="checkbox"/> Pass | <input type="checkbox"/> NG ,_____ |

**6、Summary：**

**Sales signature：** \_\_\_\_\_

**Customer Signature：** \_\_\_\_\_

**Date：** \_\_\_\_ / \_\_\_\_ / \_\_\_\_